



Chapter 2 Mobility Management for GPRS and UMTS

Associate Prof. Yuh-Shyan Chen
Department of CSIE
National Chung Cheng University
Feb. 2006



Outline

- 2.1 Network Architectures
- 2.2 Concepts of Mobility Management
- 2.3 Mobility Management States
- 2.4 MM and PDP Contexts
- 2.5 Attach and Detach
- 2.6 Location Update
- 2.7 Serving RNC Relocation
- 2.8 UMTS-GPRS Intersystem Change



Abstract

- **Chapter 2** introduces mobility management evolution from General Packet Radio Service (GPRS) to Universal Mobile Telecommunications System (UMTS).
- In GPRS, some radio management functions are handled in the core network.
- These functions have been moved to the radio access network in UMTS.
- This architectural change results in a clean design that allows radio technology and core network technology to develop independently.
- The GPRS mobility management functionality has been significantly modified to accommodate UMTS.
- This chapter emphasizes the differences between the GPRS and the UMTS procedures.



Cont.

- *Universal Mobile Telecommunications System (UMTS)* is a mobile telecommunications network that evolved from Global System for Mobile Communications (GSM) and *General Packet Radio Service (GPRS)*.
- This chapter describes the network architectures of GPRS and UMTS and shows how mobility management evolves from GPRS to UMTS.



2.1 Network Architectures

- The GSM network
 - *Mobile Stations (MSs)*; the mobile terminals) that communicate with the network through the *Base Station System (BSS)*
 - The BSS consists of the *Base Transceiver Station (BTS)* and the *Base Station Controller (BSC)*.
 - The BTS communicates with the MS through the radio interface *Um*, based on the Time Division Multiple Access (TDMA) technology.
 - Through the *A-bis* interface, the BTS connects to the BSC. The BSC communicates with exactly one *Mobile Switching Center (MSC)* via the *A* interface.



GPRS/GSM Architecture

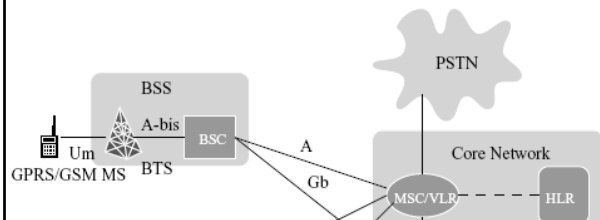

Cont.



- MSC is a special telephone switch tailored to support mobile applications. The MSC connects the calls from the MSs to the *Public Switched Telephone Network (PSTN)*.
- The *Home Location Register (HLR)* and the *Visitor Location Register (VLR)* provide mobility management, elaborated later.
- GPRS evolved from GSM, where existing GSM nodes such as BSS, MSC, VLR, and HLR are upgraded.

Cont.



- GPRS introduces two new *Core Network* nodes: *Serving GPRS Support Node (SGSN)* and *Gateway GPRS Support Node (GGSN)*.
 - The GGSN provides connections and access to the integrated services Internet.
 - It maintains routing information for the GPRS-attached MSs to tunnel *Protocol Data Units (PDUs)* to the SGSN through the *Gn* interface.
 - The GGSN communicates with the HLR for session management (see Chapter 3) through the *Gc* interface. Note that in most commercial products, the GGSN communicates with the HLR indirectly through the SGSN.

GPRS Core Network

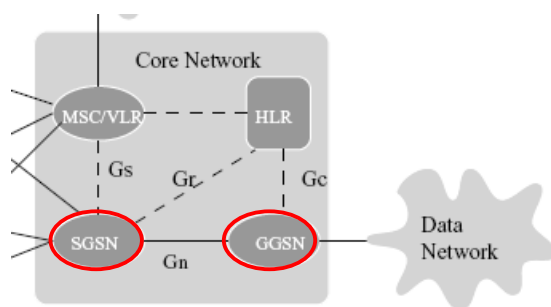

Cont.



- The SGSN is responsible for the delivery of packets to the MSs within its service area. The SGSN performs *security, mobility management, and session management functions* by communicating with the HLR through the *Gr* interface.
- The BSC of the GPRS BSS is connected to the SGSN through the *Gb* interface using the frame relay link.
- UMTS evolved from GPRS by replacing the radio access network.
 - The *UMTS Terrestrial Radio Access Network (UTRAN)* consists of **Node Bs** (the UMTS term for BTS) and *Radio Network Controllers (RNCs)* connected by an ATM network.

UTRAN

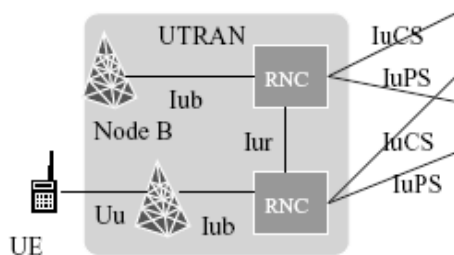
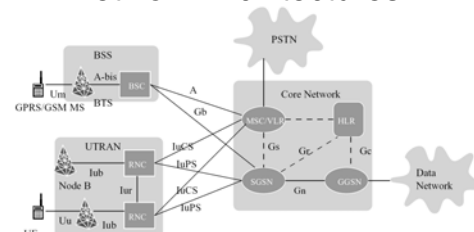

Fig. 2.1 GSM/GPRS/UMTS Network Architectures



- | | |
|--------------------------------|--|
| BSS: Base Station Subsystem | BTS: Base Transceiver Station |
| HLR: Home Location Register | GGSN: Gateway GPRS Support Node |
| MS: Mobile Station | MSC: Mobile Switching Center |
| Node B: Base Station | PSTN: Public Switched Telephone Network |
| RNC: Radio Network Controller | SGSN: Serving GPRS Support Node |
| UE: User Equipment | UTRAN: UMTS Terrestrial Radio Access Network |
| VLR: Visitor Location Register | |

Cont.



- The RNC and the Node B serving an MS are called the *Serving Radio Network Subsystem (SRNS)*.
- The *User Equipment (UE)*; the UMTS term for MS) connects with Node Bs through the radio interface *Uu* based on the *WCDMA (Wideband Code Division Multiple Access) technology*
- In UMTS, every Node B is connected to an RNC through the *Iub* interface.
- Every RNC is connected to an SGSN through the *IuPS* interface, and to an MSC through the *IuCS* interface.

Cont.



- An RNC may connect to several RNCs through the *Iur* interface.
 - Unlike the RNCs in UMTS, the BSCs in GPRS/GSM do not connect to each other.
 - The IuCS, IuPS, Iub, and Iur interfaces are implemented on the ATM network.
- The core network consists of two service domains: the *circuit-switched (CS)* service domain (that is, PSTN/ISDN) and the *packet-switched (PS)* service domain (that is, the Internet).

Cont.



- In the **CS** domain, an MS is identified by *International Mobile Subscriber Identity (IMSI)* and *Temporary Mobile Subscriber Identity (TMSI)*.
- In the **PS** domain, an MS is identified by **IMSI** and *Packet TMSI (P-TMSI)*.
- Three operation modes are defined for GPRS MS:
 - **Class A MS** allows simultaneous CS and PS connections.
 - **Class B MS** provides automatic choice of CS or PS connection, but only one at a time.
 - **Class C MS** supports only PS connection.

Cont.



- Three operation modes are defined for UMTS UE:
 - **PS/CS mode UE** is equivalent to GPRS Class A MS.
 - **PS mode UE** is equivalent to GPRS Class C MS.
 - **CS mode UE** can attach to the CS domain only.

Cont.



- In terms of the core network evolution from GPRS to UMTS, **both the SGSN and the MSC need to be modified**.
 - The *Mobility Management (MM)* and the *Packet Data Protocol (PDP)* contexts of the SGSN and the MS are modified
 - Other core network nodes such as HLR (specifically, HLR packet domain subscriber data), VLR (specifically, VLR and SGSN association, described later), and GGSN (specifically, PDP contexts) are basically the same.

Fig. 2.2 Control Planes for UMTS and GPRS

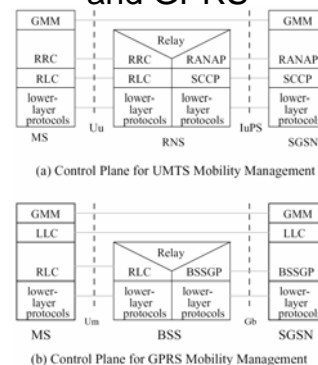

Cont.



■ Figure 2.2 illustrates the mobility management **control planes** between the MS and the SGSN for UMTS and GPRS, respectively.

- In the early GPRS version, the control plane was called the **signaling plane**.

■ The protocol stack for GPRS is

- **Radio Link Control (RLC)** provides services for information transfer over the GPRS physical layer. These functions include backward error correction procedures, enabled by the selective retransmission of erroneous blocks.
- **Logical Link Control (LLC)** is a sublayer of OSI layer 2 (see Section 8.1). LLC conveys information between layer 3 entities in the MS and SGSN. It provides services to the GMM. The LLC support to session management is described in Chapter 3.

Control Plane for GPRS

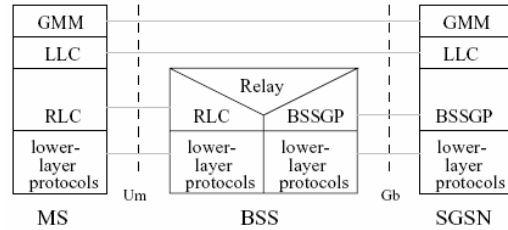

(b) Control Plane for GPRS Mobility Management

Cont.



- **GPRS Mobility Management (GMM)** supports mobility management functionality (**attach**, **detach**, and **location update**, described in Sections 2.5 and 2.6).
- **BSS GPRS Protocol (BSSGP)** provides the radio-related QoS and routing information required to transmit user data between a BSS and an SGSN.

Control Plane for UMTS



■ Unlike GPRS, the LLC layer is not supported in UMTS.

- In GPRS, reliable communication between the MS and the SGSN is guaranteed by the LLC.
- In UMTS, the **Radio Resource Control (RRC)** protocol is responsible for reliable connection between an MS and the UTRAN.
 - The **Signaling Connection Control Part (SCCP)** (see Chapter 8) is responsible for reliable connection between the UTRAN and the SGSN.
 - On top of the SCCP, the **Radio Access Network Application Part (RANAP)** protocol supports **transparent mobility management signaling transfer** between the MS and the core network.

Control Plane for UMTS

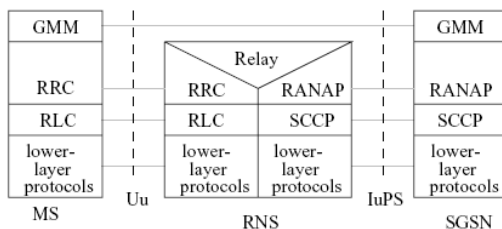

(a) Control Plane for UMTS Mobility Management

Cont.



– The RANAP is also responsible for **servicing RNC relocation** (see Section 2.7), **Radio Access Bearer (RAB)** management, and so on.

- GMM for UMTS is also referred to as **UMTS MM (UMM)**.
- The MM messages are exchanged among GPRS/UMTS nodes through various interfaces described as follows:

Cont.



● **MS and SGSN.**

- In GPRS, the **MM messages** are delivered through the **Gb** and **Um** interfaces.
- In UMTS, the **MM message** transmission is performed through the **Iu** and the **Uu** interfaces.
- Specifically, an LLC link provides a **signaling connection** between the MS and the SGSN in GPRS.
- In UMTS, the **signaling connection** consists of an RRC connection between the MS and UTRAN, and an **Iu** connection (“one RANAP instance”) between the UTRAN and the SGSN.

Fig. 2.1 GSM/GPRS/UMTS Network Architectures

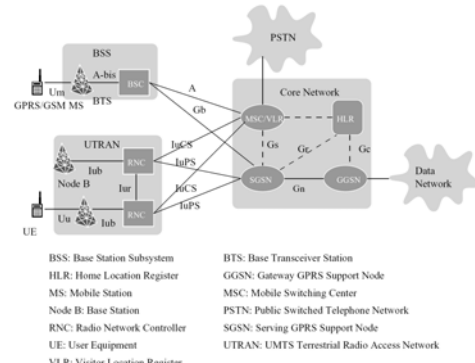

Cont.



■ **SGSN and other core network nodes:**

- In both GPRS and UMTS, **GSM Mobile Application Part (MAP)** is used to interface an SGSN with the GSM nodes—
 - for example, *Gr* for HLR, and *Gs* (the BSSAP+ protocol or *BSS Application Protocol+*) for MSC/VLR.
- An SGSN and a GGSN communicate using the **GPRS Tunneling Protocol (GTP)** through the *Gn* interface by using a **GTP tunnel** for packet delivery.
- This tunnel is identified by a **Tunnel Endpoint Identifier (TEID)**, an **Internet Protocol (IP)** address, and a UDP port number.
 - Details of the MAP protocols and GTP are described in Chapters 4, 7, and 8.

Cont.



■ For example, LA update is performed for CS, and RA update is performed for PS.

- To save radio resources, execution of similar procedures for both CS and PS can be combined.
- Furthermore, activities such as CS paging can be performed by using the PS mechanism, so that the MS only needs to monitor a single paging channel.
- The above optimizations are achieved only if the **Gs** interface exists.
 - The SGSN and the MSC/VLR can communicate to combine both PS and CS activities.

Cont.



■ The GPRS (UMTS) network is in **Network Mode I** if the **Gs** interface exists.

- Otherwise, it is in **Network Mode II**.
- Note that an extra network mode (Mode III) is defined for GPRS when the *Gs* is not present. This network mode has been removed from the UMTS specifications.

Cont.



■ **Protocols for user data transmission** are defined in the **user plane**.

- In the early GPRS version, the user plane was called the **transmission plane**.
- In GPRS, the **Sub-Network Dependent Convergence Protocol (SNDCP)** carries out transmission of **Network Protocol Data Units (N-PDUs)** on top of the LLC link between the MS and the SGSN.
- In UMTS, the **Packet Data Convergence Protocol (PDCP)** carries out N-PDU transmission on top of the RLC connection between the MS and the UTRAN, and the **GTP-U** (GTP for the user plane) protocol carries out transmission of N-PDUs on top of the UDP/IP link (**Iu** link).

Fig. 2.2 Control Planes for UMTS and GPRS

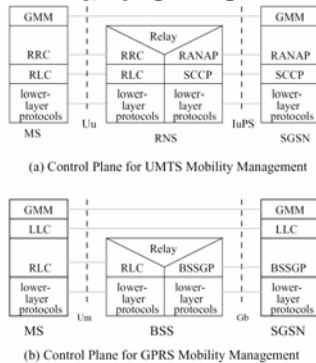

Cont.

- In both GPRS and UMTS, **IMSI** is used as the common user identity, and common MAP signaling is applied to both systems as well as GSM.
 - Unlike GPRS, the **UMTS radio network parameters and radio resources are managed in the UTRAN.**
 - Like the GPRS BSS, **the UTRAN does not coordinate mobility management procedures** that are exercised between an MS and the core network.
 - These procedures include location management, authentication, temporary identity management, and equipment identity check.

2.2 Concepts of Mobility Management

- In order to track the MSs, the cells (i.e., BTSs/Node Bs) in the GPRS/UMTS service area are partitioned into several groups.
 - To deliver services to an MS, the cells in the group covering the MS will page the MS to establish the radio link.
- Location change of an MS is detected as follows.
 - The cells broadcast their cell identities.
 - The MS periodically listens to the broadcast cell identity, and compares it with the cell identity stored in the MS's buffer.
 - If the comparison indicates that the location has been changed, then the MS sends the location update message to the network.

Cont.

- In the CS domain, cells are partitioned into *Location Areas (LAs)*.
 - The LA of an MS is tracked by the **VLR**.
- In the PS domain, the cells are partitioned into *Routing Areas (RAs)*.
 - An RA is typically a subset of an LA.
 - The RA of an MS is tracked by the **SGSN**.
 - In GPRS, the SGSN also tracks the cell of an MS during a PS connection

Fig. 2.3 LAs, RAs, and URAs

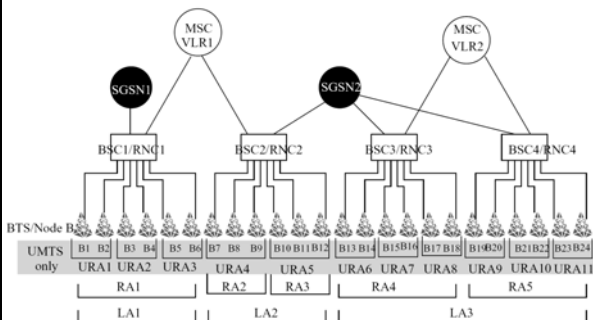

Table 2.1 Areas tracked by the network nodes

	MSC/VLR			SGSN		UTRAN
	GSM	GPRS	UMTS	GPRS	UMTS	UMTS
Cell	no	no	no	yes	no	yes
URA	-	-	no	-	no	yes
RA	-	no	no	yes	yes	no
LA	yes	yes	yes	no	no	no

Cont.



- In UMTS, the cells in an RA are further partitioned into several *UTRAN RAs (URAs)*.
- The URA and the cell of an MS are tracked by the UTRAN.
- In UMTS, the UTRAN tracking is triggered by the establishment of the RRC connection between an MS and the UTRAN, and an RRC (Radio Resource Control) state machine is executed.

RRC State Diagram

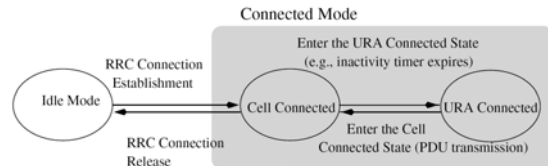

RRC state machine



- In the **RRC Idle Mode**, no RRC connection is established, and the MS is tracked by the SGSN at the RA level.
- When the RRC connection is established, the state moves from **RRC Idle** to **RRC Cell Connected**, and the MS is tracked by the UTRAN at the cell level.
- If no PDUs are transmitted before an *inactivity timer* expires, the state moves from **RRC Cell Connected** to **RRC URA Connected**, and the MS is tracked by the UTRAN at the URA level.

The mobility management functions emphasizing **PS**-based services



- **PS attach procedure** allows an MS to be "known" by the PS service domain of the network.
 - For example, after the MS is powered on, the PS attach procedure must be executed before the MS can obtain access to the PS services.
- Note that the term "PS attach" is used in UMTS and the term "GPRS attach" is used in GPRS.
 - Similarly, we have the term "CS attach" for UMTS and "IMSI attach" for GPRS.
 - For the discussion here, we use the terms PS attach and CS attach.

Cont.



- **PS detach procedure** allows the MS or the network to inform each other that the MS will not access the SGSN-based services. PS attach and detach are described in Section 2.5.
- **Security procedures** include authentication, user identity confidentiality (for example, P-TMSI reallocation and P-TMSI signature) and ciphering.

Cont.



- **Location management procedures** track the location of an MS. These procedures are elaborated in Section 2.6.
- **Tunneling of non-GSM signaling message procedures** supports communication between GPRS/UMTS and non-GSM systems such as EIA/TIA IS-136.
- **Subscriber management procedures** are used by the HLR to inform the SGSN about changes of the PS subscriber data.

Cont.



- **Service request procedure** (UMTS only) is used by the MS to establish a secure connection to the SGSN, so that the MS can send uplink signaling messages or user data.
- **UMTS-GPRS intersystem change procedures** allow a dual-mode MS to move between GPRS and UMTS systems.

2.3 Mobility Management States



- In GPRS and UMTS, an MM *Finite State Machine (FSM)* is exercised in both an MS and the SGSN to characterize the mobility management activities for the MS.
 - In GPRS, the states in the machine are **IDLE**, **STANDBY**, and **READY**.
 - For the UMTS PS service domain, these states are renamed as **PMM-DETACHED**, **PMM-IDLE**, and **PMM-CONNECTED**, respectively.

Fig. 2.5 MS MM State Diagrams

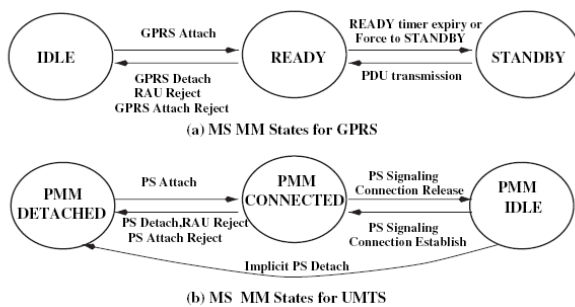

The MM states



- **IDLE or PMM-DETACHED:** The MS is not known (that is, not attached) to GPRS (UMTS/PS). That is, the MS is not reachable by the network.
 - In this state, the MS may perform the attach procedure.
- **STANDBY or PMM-IDLE:** The MS is attached to GPRS (UMTS/PS); that is, both the MS and the SGSN have established MM contexts.
 - In this state, the MS may perform the detach and location update procedures. The SGSN may perform the paging procedure. The MS is tracked by the SGSN at the RA level (see Table 2.1).

Cont.



- **READY or PMM-CONNECTED:** PDUs can only be delivered in this state.
 - In GPRS, the SGSN tracks the MS at the cell level.
 - In UMTS, a PS signaling connection is established between the MS and the SGSN (that is, the MS is in the **RRC Connected Mode**).
 - The SGSN tracks the MS with accuracy of the RA level, and the serving RNC is responsible for cell-level tracking. In UMTS, the serving RNC relocation (see Section 2.7) is executed in this state.

The transitions among the MM states



- **IDLE → READY (PMM-DETACHED → PMM-CONNECTED):**
 - This transition is triggered by the MS when the MS performs **GPRS/PS attach**.
- **STANDBY → IDLE (PMM-IDLE → PMM-DETACHED):**
 - This transition can be triggered by the MS or the SGSN:
 - This transition is triggered by the **SGSN** when tracking of the MS is lost. In this case, the SGSN performs an *implicit GPRS/PS detach*.

Fig. 2.5 MS MM State Diagrams

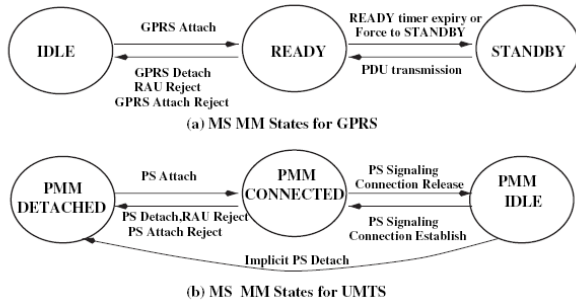

Cont.

- This transition may also be triggered by the **SGSN** when the SGSN receives the Cancel Location (de-registration) message from the HLR.
- This transition may also be triggered by the **SGSN** when the SGSN receives the Cancel Location (de-registration) message from the HLR.

Fig. 2.5 SGSN MM State Diagrams

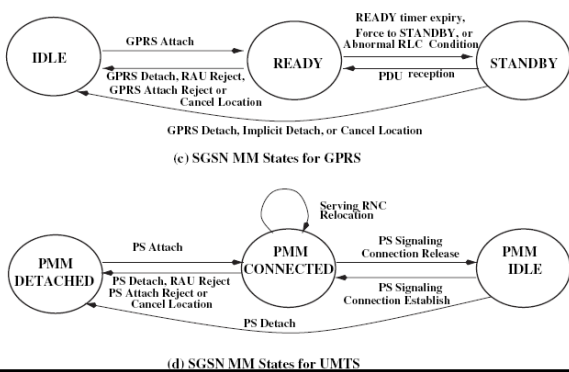

Cont.

- **STANDBY → READY (PMM-IDLE → PMM-CONNECTED).**
 - See text book.
- **READY → STANDBY (PMM-CONNECTED → PMM-IDLE).**
 - See text book.
- **READY → IDLE (PMM-CONNECTED → PMM-DETACHED).**
 - See text book.

2.4 MM and PDP Contexts

- Two important contexts are defined in GPRS/UMTS:
 - **Mobility Management (MM) context** provides mobility about an MS.
 - **Packet Data Protocol (PDP) context** provides information packet delivery between an MS and the network.

2.4.1 Contexts in SGSN

- The following fields in the **MM context** are maintained in both GPRS SGSN and UMTS SGSN:
 - *Mobile Station ISDN Number (MSISDN)*; telephone number of the MS),
 - **IMSI** (used to identify the MS in the GSM/GPRS/UMTS network; unlike
 - MSISDN, IMSI is not known to the users, and is used in the network only),
 - MM state (see Section 2.3),
 - P-TMSI, P-TMSI signature (temporarily identities of the MS; usage of these identities are described in Section 2.5),
 - *International Mobile Equipment Identity (IMEI)*; the serial number of the handset or mobile equipment),

Cont.



- routing area (see Section 2.2),
 - VLR number (associated VLR address),
 - MS network access capability
 - new SGSN address
 - selected ciphering algorithm
 - subscribed charging characteristics, and
 - several flags.
- The following MM context fields are different in GPRS SGSN and UMTS SGSN:
- **Location Information.**
 - **Security Information.**
 - **Radio Resource Information.**

Cont.



- The following fields in a **PDP context** are maintained in both GPRS SGSN and UMTS SGSN:
- PDP Route Information includes PDP context identifier, PDP state, PDP type, and PDP address.
 - Access Point Name (APN) Information includes the APN subscribed
 - and the APN in use.
 - QoS Information includes QoS profile subscribed,
 - N-PDU Information includes GTP-SND and GTP-SNU.
 - Charging Information includes the charging identifier.

Cont.



- Other Routing Information includes NSAPI, TI, TEID for Gn/Gp, GGSN address in use, and VPLMN address allowed. *Network Layer Service Access Point Identifier (NSAPI)* is used by LLC (in GPRS) or RLC (in UMTS) to route the N-PDUs to appropriate higher layer protocols such as signaling, SMS, or packet data protocols. *Transaction Identifier (TI)* is used to represent NSAPI for some session management signaling messages. VPLMN specifies the GPRS/UMTS networks visited by the MS.
 - Subscribed Charging Characteristics can be normal, prepaid, flat-rate, and/or hot billing. In the early GPRS/UMTS version, charging characteristics for PDP contexts are maintained in the SGSN. In the latest version, charging characteristics are included in the SGSN MM context.
- The following PDP context fields are different in GPRS SGSN and UMTS SGSN:
- **Core Network to Radio Access Network Connection.**
 - **Radio Resource Information.**
 - **PDU Information.**

Relationship between the MM states and the contexts



Context	IDLE/DETACHED			STANDBY/IDLE			READY/CONNECTED		
	MS	SGSN	GGSN	MS	SGSN	GGSN	MS	SGSN	GGSN
MM	x/Δ	x/Δ	-	○	○	-	○	○	-
PDP	x/Δ	x/Δ	x	x/○	x/○	x/○	x/○	x/○	x/○

Δ: The context is kept but is stale. x: The context is removed.
 -: The context does not exist. ○: The current context is maintained.

2.5 Attach and Detach



- With the attach procedure, the MS informs the network of its presence.
- Figure 2.6 illustrates the message flow of the combined PS/CS (GPRS/IMS) attach procedure.

Fig. 2.1 GSM/GPRS/UMTS Network Architectures

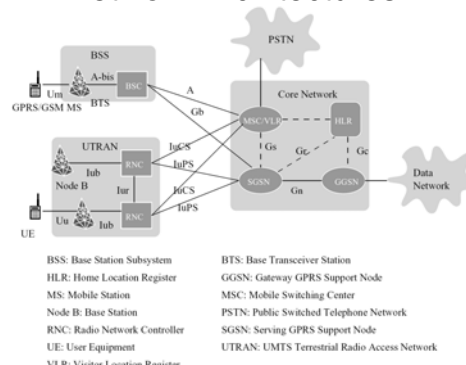

Step 1.



- The MS initiates the attach procedure by sending the **Attach Request** message to the new SGSN.
- In GPRS, besides the MS network access capability, the message includes parameters such as **MS radio access capability**.
 - These radio-related parameters are not included in the UMTS Attach Request message.
- Conversely, the UMTS message includes the “**follow on request**” parameter to indicate whether there is pending uplink traffic that needs **lu** connection after the attach procedure is completed.
 - This field is not needed in GPRS because the **lu** interface does not exist. Furthermore, as we previously mentioned, the security parameters for UMTS and GPRS are different.

Fig. 2.6 Combined PS/CS (GPRS/IMSI) Attach Procedure

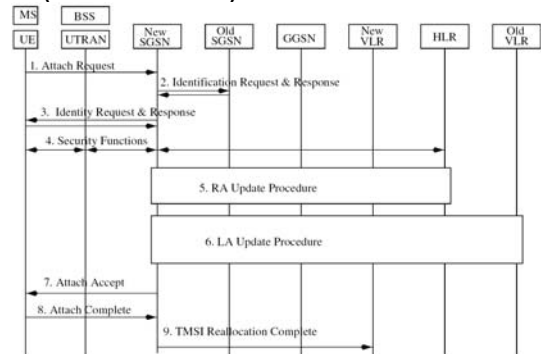

Cont.



- When the SGSN receives the attach request at the end of Step 1, several results are possible:
 - If the MS has **changed SGSN** since the last detach, then **Step 2** is executed so that the new SGSN can obtain the MS identity (that is, IMSI) from the old SGSN.
 - If the MS has not changed SGSN, then the received **P-TMSI** is used by the SGSN to identify the MM context of the MS.
 - If the **MM context** has not been deleted since the last detach (that is, the MS is known by the new SGSN), then Steps 2–6 are skipped, and Step 7 is executed.
 - Otherwise (the MS is not known by the old and the new SGSNs), Step 2 is skipped, and Step 3 is executed.

Step 2 (the MS is known by the old SGSN).



- The new SGSN sends the **Identification Request message** to the old SGSN.
- The P-TMSI is used to obtain the IMSI and authentication information from the old SGSN.
- If the old SGSN cannot find the MM context for the MS, then Step 3 is executed.
- Otherwise, the IMSI is returned to the new SGSN, and Step 4 is executed.

Combined PS/CS (GPRS/IMSI) Attach Procedure

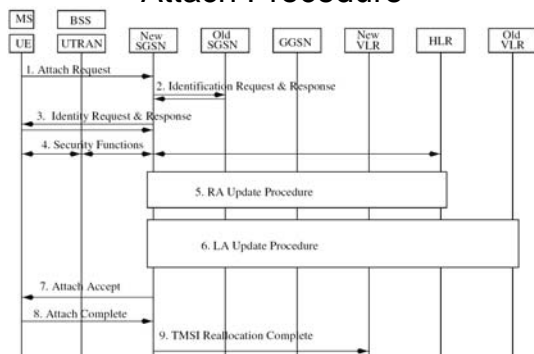

Step 3 (the MS is unknown to both the old and the new SGSN)



- The new SGSN asks the MS to supply IMSI through the **Identity Request and Response** messages exchange.

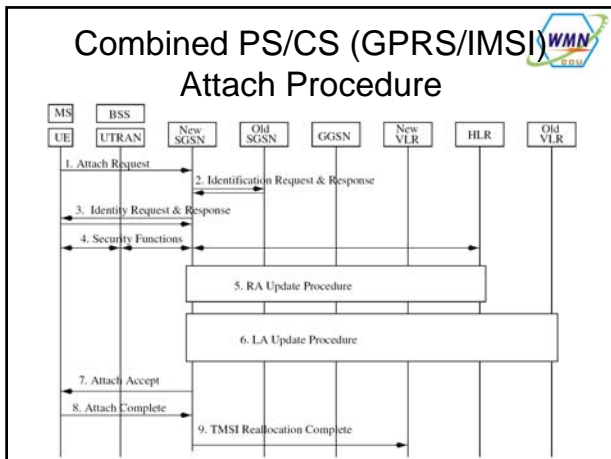

Step 4.

- Authentication is mandatory if the MM context of the MS has been deleted since the last detach. The **IMEI** of the MS may be optionally checked.

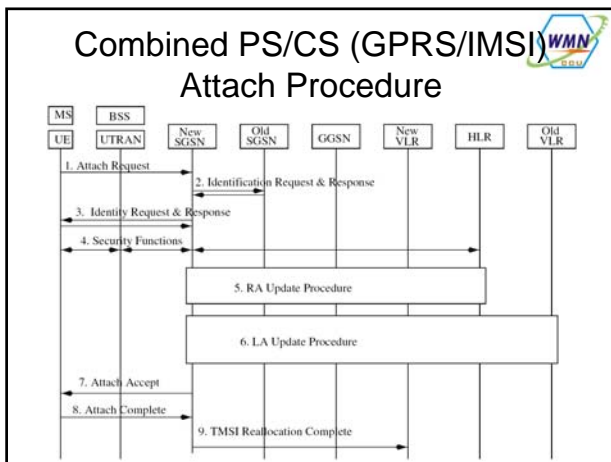

Step 5.

- If the MS has moved from the old SGSN to the new SGSN since the last detach or if the MS is performing the first attach, then the **RA update procedure** is executed
 - so that the **new SGSN can obtain the current MM context** of the MS.
 - This step is the same as Steps 6–9 in Figure 2.7.

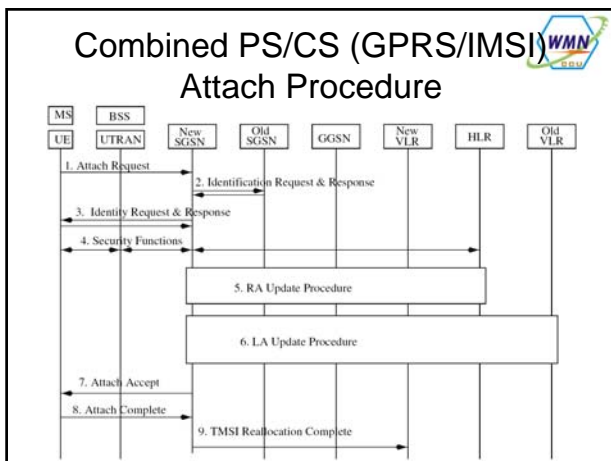

Step 6.

- If the **Gs** interface does not exist, then this step is skipped. Otherwise, the attach type in Step 1 is checked.
- If the attach type indicates (1) combined PS/CS attach or (2) PS attach and the MS is already CS attach, then **LA update** is performed.
- The LA update is required so that the SGSN-VLR association is established and the VLR can maintain current LA information of the MS. This step is the same as Steps 10–12 in Figure 2.7.

Combined PS/CS (GPRS/UMTS) Attach Procedure

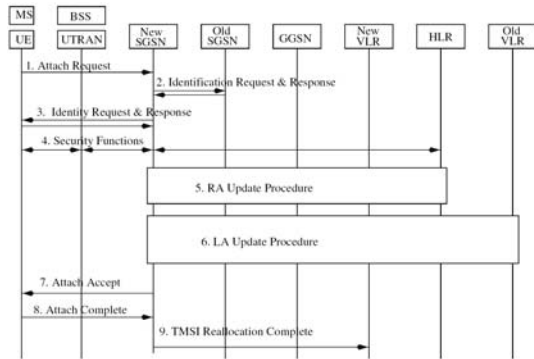

Step 7.

- For GPRS, if attach is successful, then the SGSN selects radio priority SMS and sends the **Attach Accept** message to the MS.
 - **P-TMSI** is included in the message if the SGSN allocates a new P-TMSI.
 - In UMTS, radio priority SMS is not maintained in mobility management. However, this parameter is still reserved in the UMTS Attach Accept message in order to support handoff between UMTS and GSM networks [3GP05f].

Combined PS/CS (GPRS/UMTS) Attach Procedure

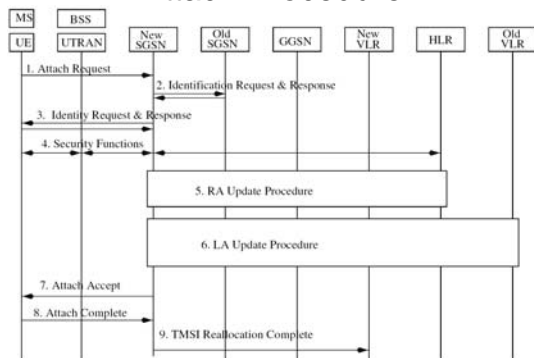

Steps 8 and 9.

- If P-TMSI or TMSI have been changed, the MS sends the **Attach Complete** message to the SGSN to acknowledge receipt of the TMSIs.
 - The SGSN sends the **TMSI Reallocation Complete message** to the VLR.

Cont.

- After PS attach, the MS is in the **READY** (for GPRS) or the **PMMCONNECTED** (for UMTS) state and MM contexts are established in the MS and the SGSN.

2.6 Location Update

- In location management, the MS informs the network of its location through RA and LA update procedures.
- The update procedures are executed in two situations:
 - **Normal location update** is performed when the MS detects that the location has been changed.
 - **Periodic location update** is exercised even if the MS does not move.
 - That is, the MS periodically reports its "presence" to the network.

Cont.



- Periodic RA update enables the network to detect whether an MS is still attached to the network.
 - A *periodic RA update timer* is maintained in both the MS and the SGSN.
 - Every time this timer expires, the MS performs a periodic RA update.
 - The periodic RA update timer value is set/changed by the SGSN, and is sent to the MS through the **RA Update Accept** or the **Attach Accept** messages when the MS visits an RA.
 - This value cannot be changed before the MS leaves the RA.

Cont.



- **RA update** is periodically performed for a PS-attached MS that is not CS attached (see Table 2.3).
- Conversely, **LA update** is periodically performed for a CS-attached MS that is not PS-attached.
- For a PS/CS attached MS, two cases are considered:
 - **The MS is not engaged in a CS connection** (see Table 2.3).
 - **The MS is engaged in a CS connection.**

Table 2.3 RA/LA update (the MS is not engaged in CS connection.)



NETWORK MODE	MODE I	MODE II
PS Attached	RA update	RA update
CS Attached	LA update	LA update
PS/CS Attached	RA update (periodic) combined RA update (normal)	Separate LA and RA updates

The MS is engaged in a CS connection.



- During a CS connection, the network knows that the MS is attached, and no periodic location update is performed.
- In terms of normal location update, two cases are considered (see Table 2.4):
 - **Class A MS (GPRS) or PS/CS MS (UMTS).**
 - **Class B MS (GPRS only).**

Class A MS (GPRS) or PS/CS MS (UMTS)



- During a CS connection
 - RA update is exercised when the MS changes RAs.
 - LA update is not performed when the MS changes LAs.
- Suppose that only inter-RA crossings occur during a CS connection, then at the end of the CS connection, no action is required.

Table 2.4 RA/LA update (the MS is engaged in CS connection.)



MS MODE	CLASS A (PS/CS)		
Movement Type	Inter-RA	Inter-SGSN	Inter-LA
During CS Connection	RA update	RA update	No action
Connection Release (Mode I)	No action	Combined RA/LA update	Combined RA/LA update
Connection Release (Mode II)	No action	No action	LA update

Cont.



- For Network Mode I, if there are inter-SGSN or inter-LA crossings during a CS connection, then at the end of the CS connection, a combined RA/LA update is executed to modify the SGSN-VLR association.
- For Network Mode II, if there are inter-LA crossings during the CS connection, then at the end of the CS connection, an LA update is performed.

Cont.



MS MODE	CLASS B (GPRS ONLY)		
	Inter-RA	Inter-SGSN	Inter-LA
During CS Connection	No action	No action	No action
Connection Release (Mode I)	RA update	Combined RA/LA update	Combined RA/LA update
Connection Release (Mode II)	RA update	RA update	LA update

The message flow of the combined RA/LA update



- Figure 2.7 illustrates the message flow of the combined RA/LA update.
 - In each step, we point out the differences between GPRS and UMTS:

Fig. 2.7 Combined RA/LA Update

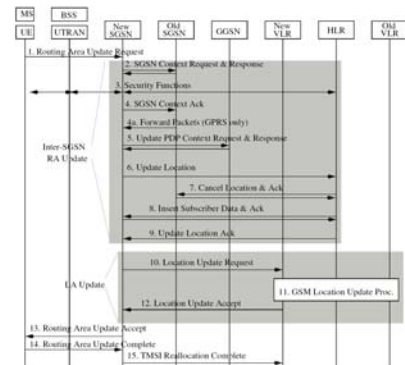

Step 1.



- The MS sends the **Routing Area Update Request** message to the new SGSN. This message is not ciphered so that the new SGSN can process the message. For both GPRS and UMTS, the update type can be **RA update**, **periodic RA update**, **combined RA/LA update**, or **combined RA/LA update with IMSI attach**.
- In this message, the "follow on request" parameter is used in UMTS to indicate whether the lu connection should be kept for pending uplink traffic. This parameter does not exist in GPRS.
 - In GPRS, before the BSS passes the message to the SGSN, it adds the cell global identity information (including cell, RA and LA identities).
 - In UMTS, the RNC adds the routing area identity information (including RA and LA identities).

Fig. 2.7 Combined RA/LA Update

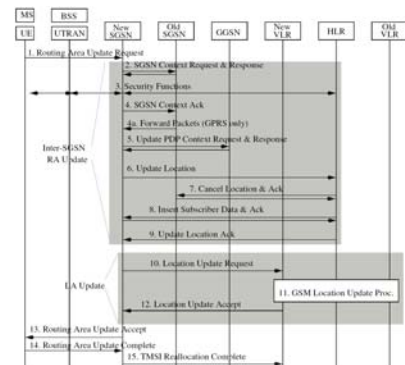

Step 2.



- To obtain the MM and the PDP contexts of the MS, the new SGSN sends the SGSN Context Request message to the old SGSN.
- Basically, the old SGSN validates the old P-TMSI signature, and returns the MM and the PDP contexts of the MS using the SGSN Context Response message.
- The old SGSN starts a timer. The MM context in the old SGSN is deleted when both of the following conditions are satisfied:

Cont.



- The timer expires.
- The old SGSN receives the Cancel Location message from the HLR.

Fig. 2.7 Combined RA/LA Update

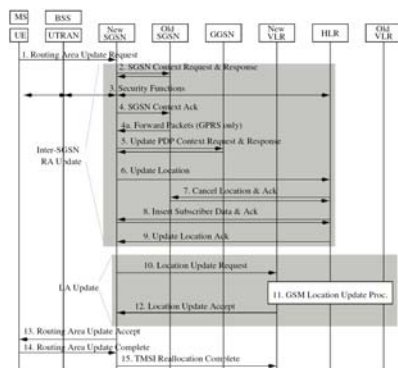

Step 3.



- If the old P-TMSI signature checking at Step 2 fails, a security function involving the MS, the BSS/UTRAN, the new SGSN, and the HLR is performed.
- If this security procedure also fails, then the old SGSN continues as though the SGSN Context Request message were never received and this procedure exits.
- Otherwise (security check succeeds), Step 4 is executed.

Fig. 2.7 Combined RA/LA Update

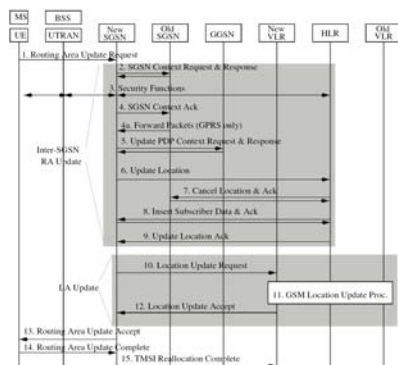

Step 4.



- The new SGSN sends the **SGSN Context Acknowledge** message to the old SGSN, which invalidates the SGSN-VLR association in the old MM context. In GPRS, this message includes the address of the new SGSN,
 - which is used to inform the old SGSN that the new SGSN is ready to receive the buffered packets to be forwarded from the old SGSN.
- The new SGSN address is not included in the UMTS SGSN Context Acknowledge message.

Fig. 2.7 Combined RA/LA Update

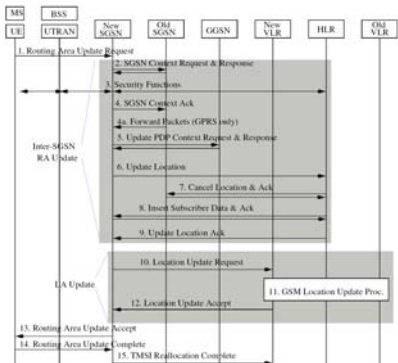

Step 4a (GPRS only).

- The old SGSN then tunnels the buffered N-PDUs to the new SGSN.
- Note that no packets are forwarded from the old SGSN to the new SGSN in UMTS.

Fig. 2.7 Combined RA/LA Update

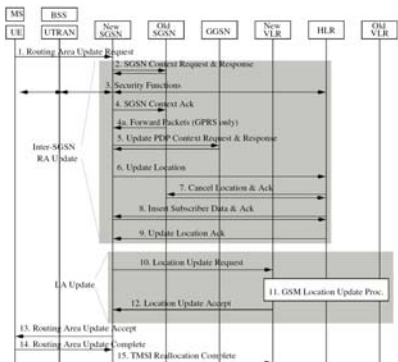

Step 5.

- The new SGSN sends the **Update PDP Context Request** message to the corresponding GGSNs.
 - With this message, the GGSN PDP contexts are modified.
 - The GGSNs return the Update PDP Context Response messages.

Fig. 2.7 Combined RA/LA Update

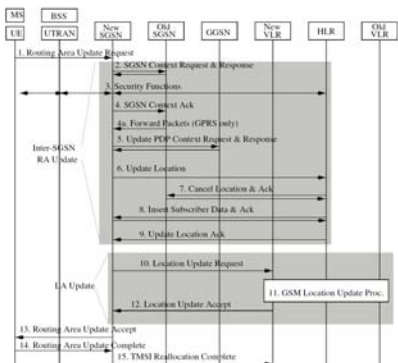

Step 6.

- The SGSN issues the **Update Location** message to inform the **HLR** that the **SGSN** for the MS has been changed.

Fig. 2.7 Combined RA/LA Update

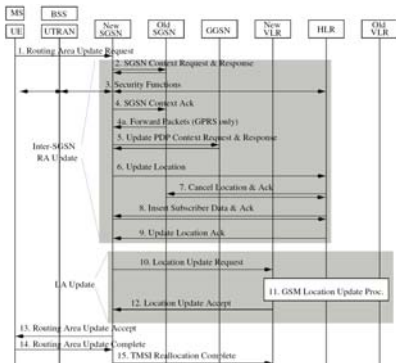

Step 7.

- The HLR and the old SGSN exchange the **Cancel Location** message pair.
- The MM and the PDP contexts in the old SGSN are not deleted until the timer described in Step 2 expires.

Fig. 2.7 Combined RA/LA Update

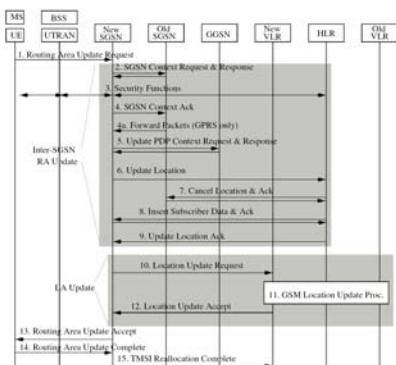

Steps 8 and 9.

- The HLR inserts the user profile (subscriber data) into the new SGSN.
- For each PDP context, the new SGSN checks whether the context is **new**, **active**, or **inactive**.
 - If the PDP context is active, then extra tasks are performed by the SGSN.
 - For example, the SGSN checks whether the received "QoS subscribed" value is the same as the value of the QoS negotiated parameter.
 - If not, the SGSN should initiate the PDP context modification procedure to adjust the QoS parameters of the context.

Fig. 2.7 Combined RA/LA Update

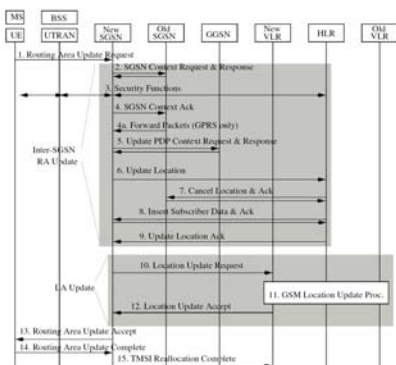

Cont.

- Steps 10–12 are executed if **the new SGSN detects that the LA has been changed** or the update type in Step 1 indicates **combined RA/LA update with IMSI (CS) attach**.

Step 10 (LA Update).



- Through a table lookup technique, the SGSN translates the **Routing Area Identifier (RAI)** into the VLR number and sends the **Location Update Request** message to the VLR.
- The VLR creates or updates the SGSN-VLR association by storing the SGSN number.

Step 11.



- The **standard GSM location update** procedure is performed.
 - The details can be found in Section 9.2.

Fig. 2.7 Combined RA/LA Update

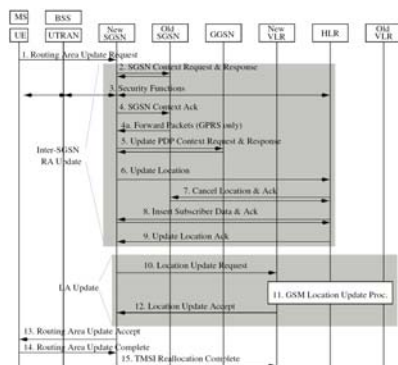

Step 12.



- The new VLR allocates a new TMSI and responds with **Location Update Accept** to the SGSN.
 - TMSI allocation is optional if the **VLR is not changed**.

Fig. 2.7 Combined RA/LA Update

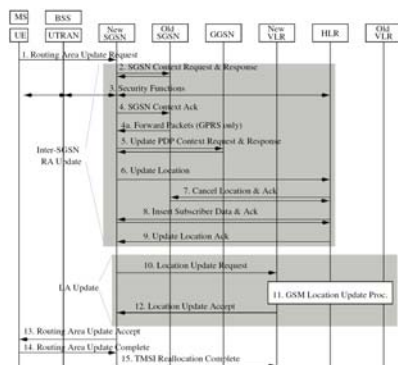

Step 13.



- The new SGSN sends the **Routing Area Update Accept** message to the MS.
- In GPRS, the new SGSN also confirms that all mobile originated N-PDUs successfully transferred before the start of the update procedure.

Fig. 2.7 Combined RA/LA Update

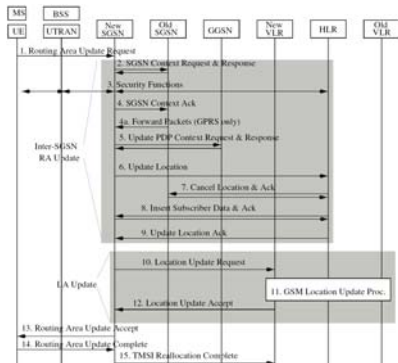

Step 14.

- The MS sends the **Routing Area Update Complete** message to the new SGSN to confirm the reallocation of the **TMSI**.
- In GPRS, the MS also confirms all received mobile-terminated N-PDUs before the RA update procedure started.
- This information is used by the new SGSN to check whether the packets forwarded from the old SGSN have been received by the MS. If so, these redundant packets are discarded.

Step 15.

- If the MS receives a new TMSI, then it sends the **TMSI Reallocation Complete** message to the VLR.

Cont.

- In terms of RA update, the major differences between UMTS and GPRS are as follows:
 - In GPRS, **packet forwarding** is performed between old and new SGSNs during **RA update**.
 - In UMTS, **packet forwarding** is handled at the **RNC** level, and the **SGSN** is not involved.
 - In the RA update, the **UMTS MS may determine whether the lu connection should be maintained** (see Step 1 in Figure 2.7), which is not needed in GPRS.

2.7 Serving RNC Relocation

- Like GPRS, packets are routed between the MS and the GGSN in UMTS.
 - An example of the routing path is illustrated in Figure 2.8 (a).
 - MS communicates with two Node Bs (B1 and B2).

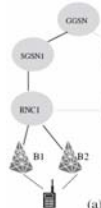

Cont.

- In WCDMA [3GP04e], an MS is allowed to transmit signals through multiple radio paths connected to different Node Bs, and the signals are merged in a network node (RNC1 in Figure 2.8 (a)).
- In a packet routing path between the core network and the MS, the RNC that directly connects to the SGSN is called the *Serving RNC (SRNC)*.
 - In Figure 2.8 (a), RNC1 is the serving RNC.

Cont.



■ If the MS moves during packet transmission, the packet routing path may be changed.

- In Figure 2.8, when the MS moves toward Node B3, the radio link between the MS and B1 is removed due to radio path loss, and the radio link between B3 and the MS is added (Figure 2.8 (b))

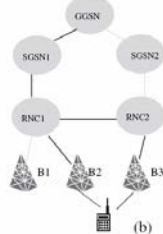

Cont.



- In this case, B3 is connected to RNC2, and an Iur link between RNC1 and RNC2 is established so that the signal received by B3 can be forwarded to RNC1 through RNC2.
- RNC1 then combines the signals from B2 and B3, and forwards it to SGSN1.
- In this case, RNC1 is the SRNC, and RNC2 is called the *Drift RNC (DRNC)*.
- The DRNC transparently routes the data through the Iub and the Iur interfaces, and only performs Layer 1 and partial Layer 2 functionality
 - for example, MAC for common and shared channels.

Cont.



- In Figure 2.8 (b), the RLC connections are defined between the SRNC and the MS, and the DRNC is bypassed.
- Suppose that the MS moves away from B2, and the radio link between the MS and B2 is disconnected. In this case, the MS does not communicate with any Node Bs connected to RNC1.
- The routing path is now MS ↔ B3 ↔ RNC2 ↔ RNC1 ↔ SGSN1 ↔ GGSN as shown in Figure 2.8 (c).
 - In this case, it does not make sense to route packets between the MS and the core network through RNC1.

Cont.

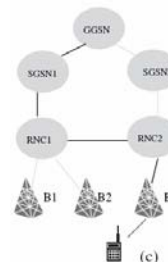

Cont.



- SRNC relocation may be performed to remove RNC1 from the routing path. Suppose that RNC2 connects to SGSN2. Then, after RNC relocation, the packets are routed to the GGSN through RNC2 and SGSN2 (Figure 2.8 (d)).

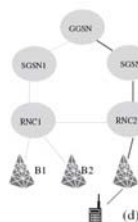

Cont.



- At this point, RNC2 becomes the serving RNC.
- SRNC relocation may also be executed when **hard handoff** occurs.
 - As shown in Figure 2.9 (a), before the relocation, the communication path is GGSN ↔ SGSN1 ↔ RNC1 ↔ B2 ↔ MS, and the MS is not connected to any Node Bs of RNC2.
 - During hard handoff and SRNC relocation, the radio link connected to the MS is switched from B2 to B3. After the relocation, the communication path is GGSN ↔ SGSN2 ↔ RNC2 ↔ B3 ↔ MS.

Fig. 2.9 Combined Hard Handoff with SRNS Relocation

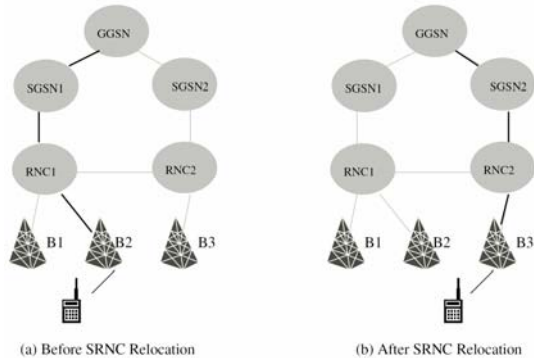

The SRNC relocation procedures for CS services

- Figure 2.10 illustrates the CS connection before and after SRNC relocation.
- Before relocation, the call path is **MSC1** ↔ RNC1 ↔ RNC2 ↔ MS.
- After relocation, the call path is **MSC1** ↔ **MSC2** ↔ RNC2 ↔ MS, and MSC1 becomes the *anchor* MSC.

Fig. 2.10 CS SRNC Relocation

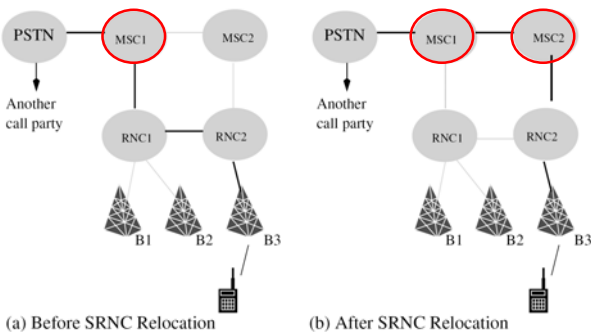

Cont.

- The SRNC relocation procedure for PS is illustrated in Figure 2.11. This
- procedure is only performed for an MS in the **PMM-CONNECTED** state.

Fig. 2.11 SRNC Relocation Message Flow for PS

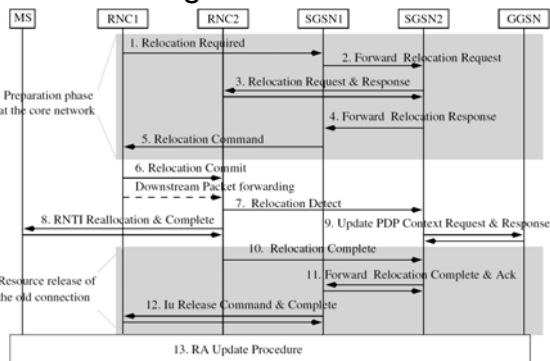

2.8 UMTS-GPRS Intersystem Change

- SGSN Change from UMTS to GPRS
- SGSN Change from GPRS to UMTS

2.8.1 SGSN Change from UMTS to GPRS

- For SGSN change from UMTS to GPRS, if the MS is in the **PMM-IDLE** state, then the **normal GPRS RA update** procedure is executed.
- If the MS makes the intersystem change decision when it is in the **PMM-CONNECTED** state, then it stops the transmission to the network.
- The following steps are executed for intra-SGSN change (see Figure 2.12):

Fig. 2.12 Intra-SGSN Change from UMTS to GPRS

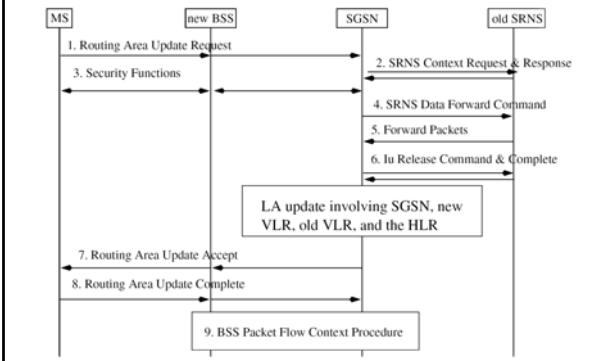

2.8.2 SGSN Change from GPRS to UMTS

- For SGSN change from GPRS to UMTS, if the MS is in the **STANDBY** state, then the **normal UMTS RA update** procedure is executed.
- If the MS makes the intersystem change decision when it is in the **READY** state, then it stops the transmission to the network by disconnecting the LLC link.
- The following steps are executed for intra-SGSN change (see Figure 2.13):

Fig. 2.13 Intra-SGSN Change from GPRS to UMTS

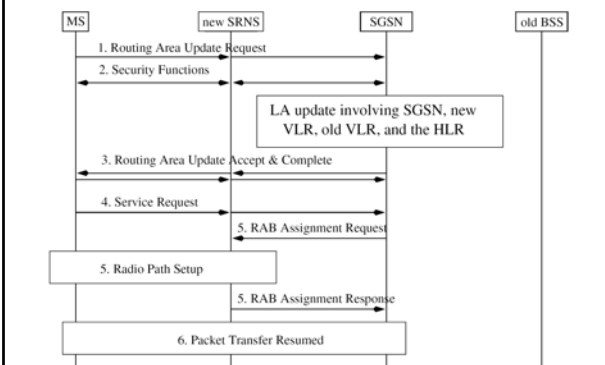

Homework 2-1:

- Draw the message flow for combined hard handoff with SRNC relocation.