



## Chapter 16 Issues for the IP Multimedia Core Network Subsystem

Associate Prof. Yuh-Shyan Chen  
Department of CSIE  
National Chung Cheng University  
June 2006



## Outline

- 16.1 Caching in I-CSCF
  - 16.1.1 Standard IMS Registration and Call Setup
  - 16.1.2 IMS Registration and Call Setup with Cache
- 16.2 Integrated Authentication for GPRS and IMS
  - 16.2.1 3GPP Two-Pass Authentication
  - 16.2.2 One-Pass Authentication Procedure
  - 16.2.3 Correctness of the One-Pass Procedure



## Abstract

- **Chapter 16** elaborates on the performance of the **IP Multimedia Core Network Subsystem (IMS)** incoming call setup, and describes the cache schemes with fault tolerance to speed up the incoming call setup process.



## Introduction

- Based on the architecture described in Chapter 15, this chapter investigates two issues for the IP Multimedia Core Network Subsystem (**IMS**).
- The first issue regards **Interrogating** Call Session Control Function (**I-CSCF**) access.
- In IMS, any incoming call will first arrive at the I-CSCF.
  - The I-CSCF queries the Home Subscriber Server (**HSS**) to identify the **Serving** CSCF (**S-CSCF**) of the called mobile user.



## Cont.

- The **S-CSCF** then sets up the call to the called mobile user.
- We also describe cache schemes with fault tolerance to speed up the incoming call setup process.



## 16.1 Caching in I-CSCF

- In UMTS, the IMS provides multimedia services by utilizing the *Session Initiation Protocol (SIP)*; see Chapter 12).
- By redrawing Figure 15.1, Figure 16.1 illustrates a simplified UMTS network architecture that emphasizes the IMS.

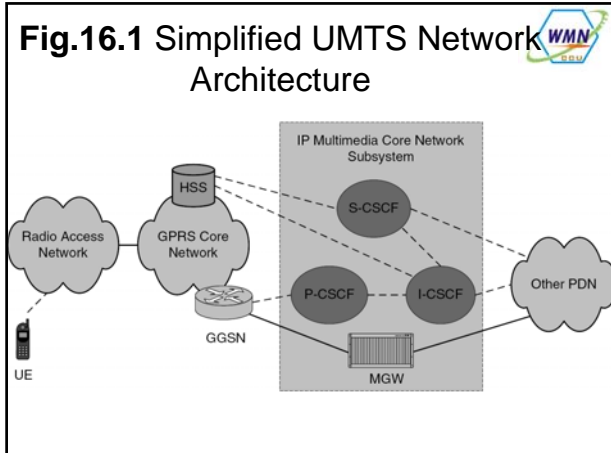

**Cont.**

- As shown in this figure, the IMS user data traffic is transported through the *Media Gateways (MGWs)*.
- As described in Chapter 15, IMS signaling is carried out by the *Proxy-Call Session Control Function (P-CSCF)*, the *Interrogating CSCF (I-CSCF)*, and the *Serving CSCF (S-CSCF)*.

**Cont.**

- The I-CSCF determines how to route incoming calls to the S-CSCF and then to the destination UEs.
  - When a UE attaches to the GPRS/IMS network and performs PDP context activation, a P-CSCF is assigned to the UE.
- The P-CSCF contains limited address translation functions to forward the requests to the I-CSCF.
  - By exercising the IMS registration, an S-CSCF is assigned to serve the UE.

**Cont.**

- This S-CSCF supports the **signaling for call setup** and **supplementary services control**.

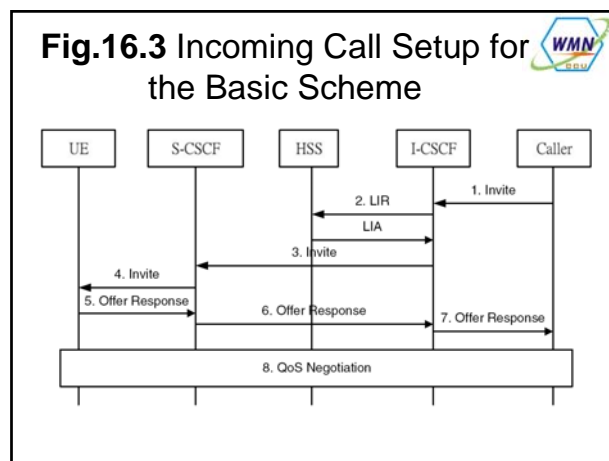
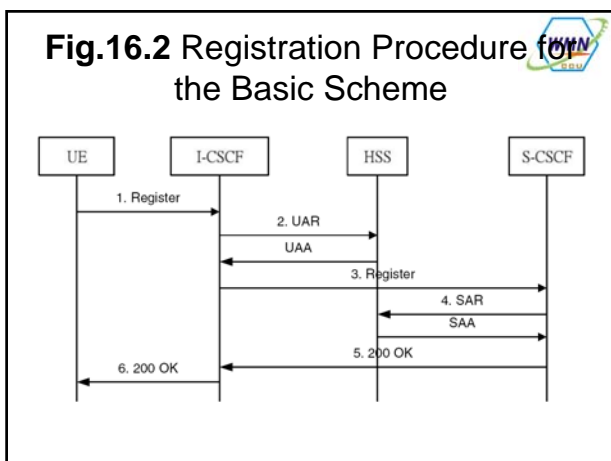

**Fig.16.4 Registration with Cache Update for the C Schemes**

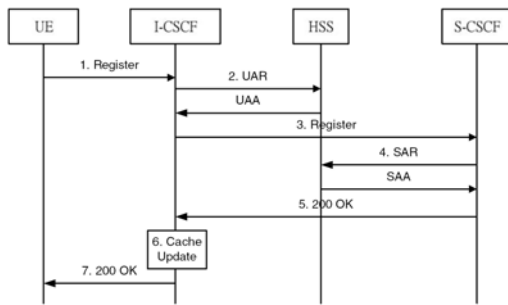

**Fig.16.5 Incoming Call Setup with Cache Retrieval for C Schemes**

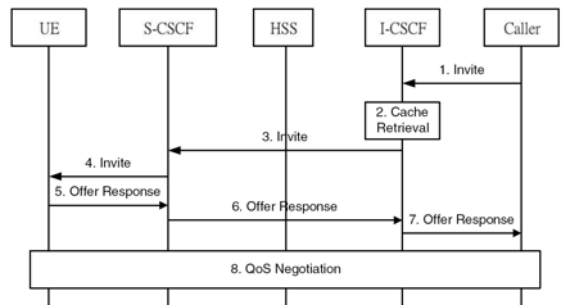

**Fig.16.6 First Incoming Call Setup after I-CSCF-Failure: Cache Miss for the Checkpoint Scheme 1**

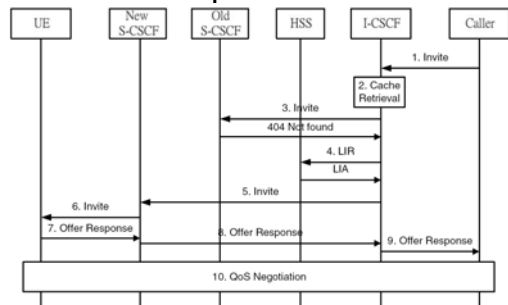

**Fig.16.7 First Incoming Call Setup after I-CSCF-Failure: Cache Miss for Checkpoint Scheme 2**

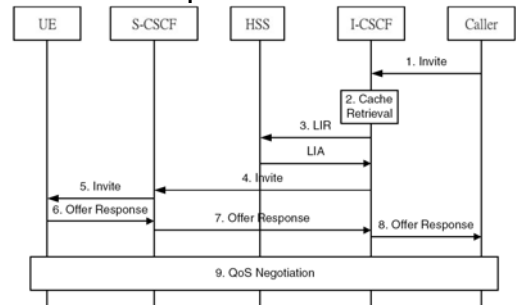

**Fig.16.8 Message Flow for the 3GPP IMS Authentication**

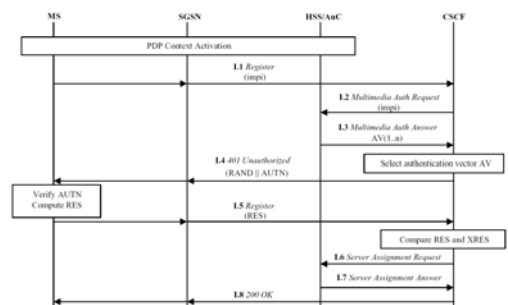

**Fig.16.9 Illegal IMS Registration**

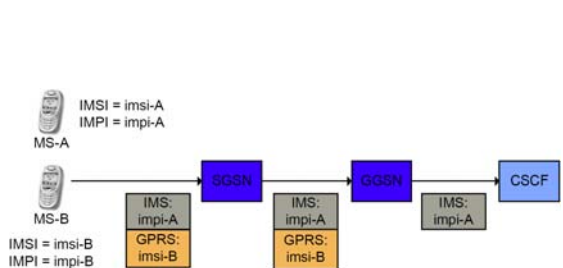

**Fig.16.10 IMS Registration**

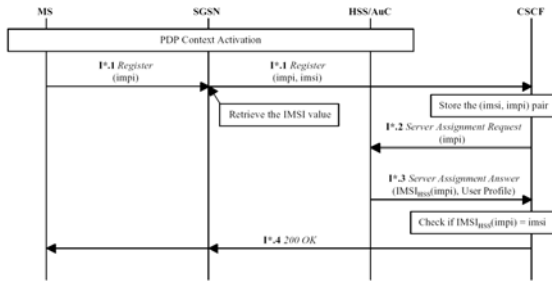

**Fig.16.11 Improvement S of the One-Pass Procedure over the Two-Pass Procedure**

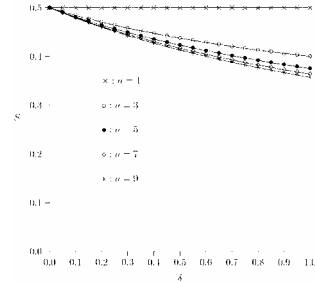

**Fig.16.12 Timing Diagram for Registration and Checkpointing**

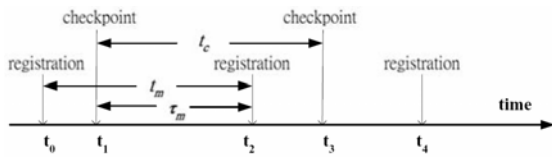

**Fig.16.13 Comparing Fixed and Exponential Checkpointing**

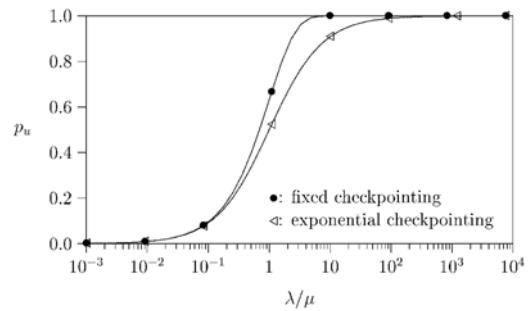

**Fig.16.14 Timing Diagram Before and After an I-CSCF Failure**

